



THE HUB

I have been crucified with Christ; it is no longer I who live, but Christ who lives in me; and the life I now live in the flesh, I live by faith in the Son of God, who loved me and gave himself for me. Galatians 2:20



OBEDIENCE

He who has my commandments and keeps them, he it is who loves me; and he who loves me will be loved by my Father, and I will love him and manifest myself to him. John 14:21

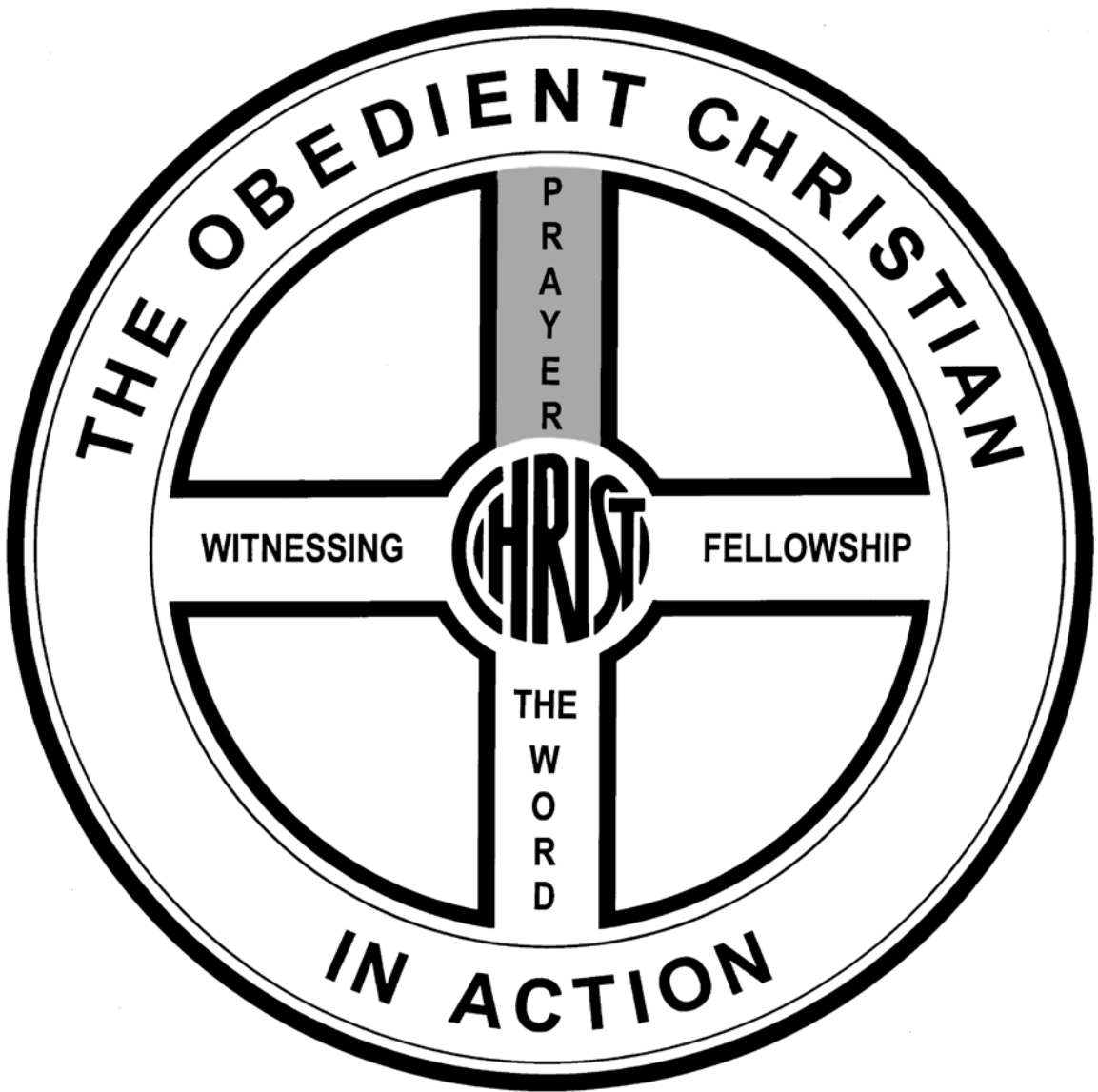

PRAYER

If you abide in me, and my words abide in you, ask whatever you will, and it shall be done for you. John 15:7



THE WORD

This book of the law shall not depart out of your mouth, but you shall meditate on it day and night, that you may be careful to do according to all that is written in it; for then you shall make your way prosperous, and then you shall have good success. Joshua 1:8



FELLOWSHIP

And let us consider how to stir up one another to love and good works, not neglecting to meet together, as is the habit of some, but encouraging one another, and all the more as you see the day drawing near. Hebrews 10:24, 25



WITNESSING

For I am not ashamed of the gospel; it is the power of God for salvation to everyone who has faith, to the Jew first and also to the Greek. Romans 1:16



And they devoted themselves to the apostle's teaching and fellowship, to the breaking of bread and to prayers. And day by day, attending the temple together and breaking bread in their homes, they partook of food with glad and generous hearts, praising God and having favor with all the people. And the Lord added to their number day by day those who were being saved.
Acts 2:43, 46, 47

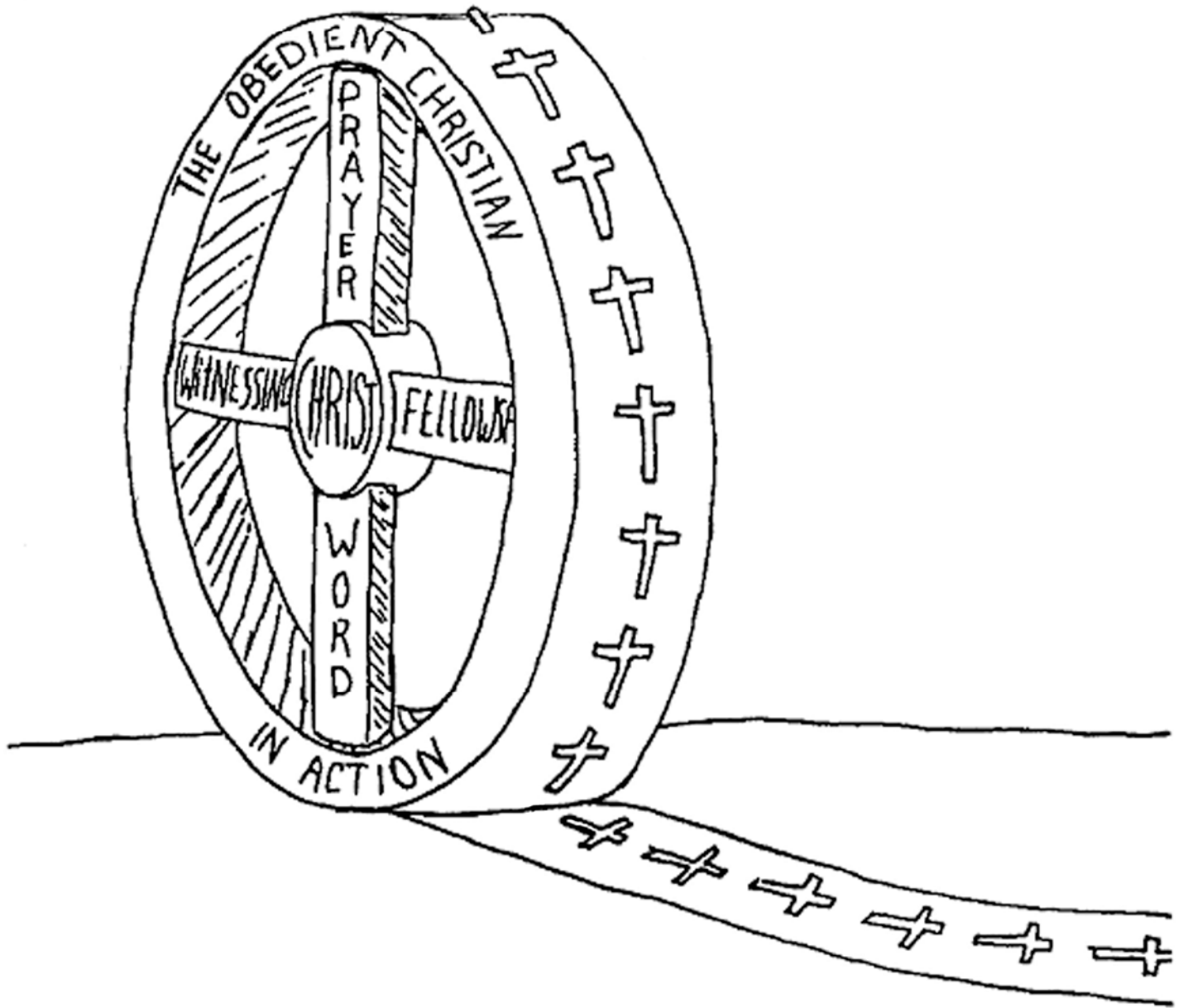

And you show that you are a letter from Christ delivered by us, written not with ink but with the Spirit of the Living God, not on tablets of stone but on tablets of human hearts. II Corinthians 3:3

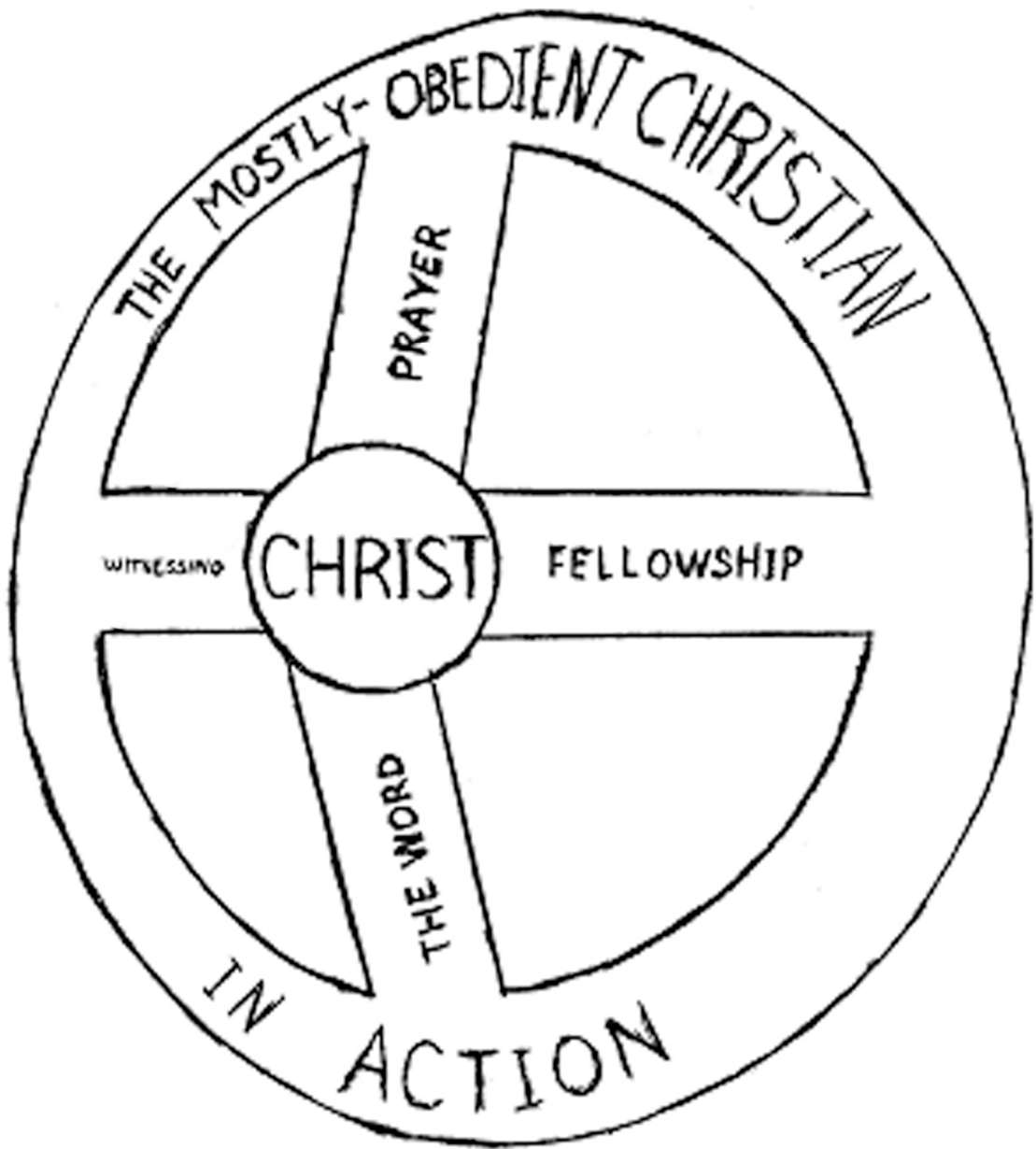

If anyone is ashamed of me and my words in this adulterous and sinful generation, the Son of Man will be ashamed of him when he comes in His Father's glory with the holy angels. Mark 8:38

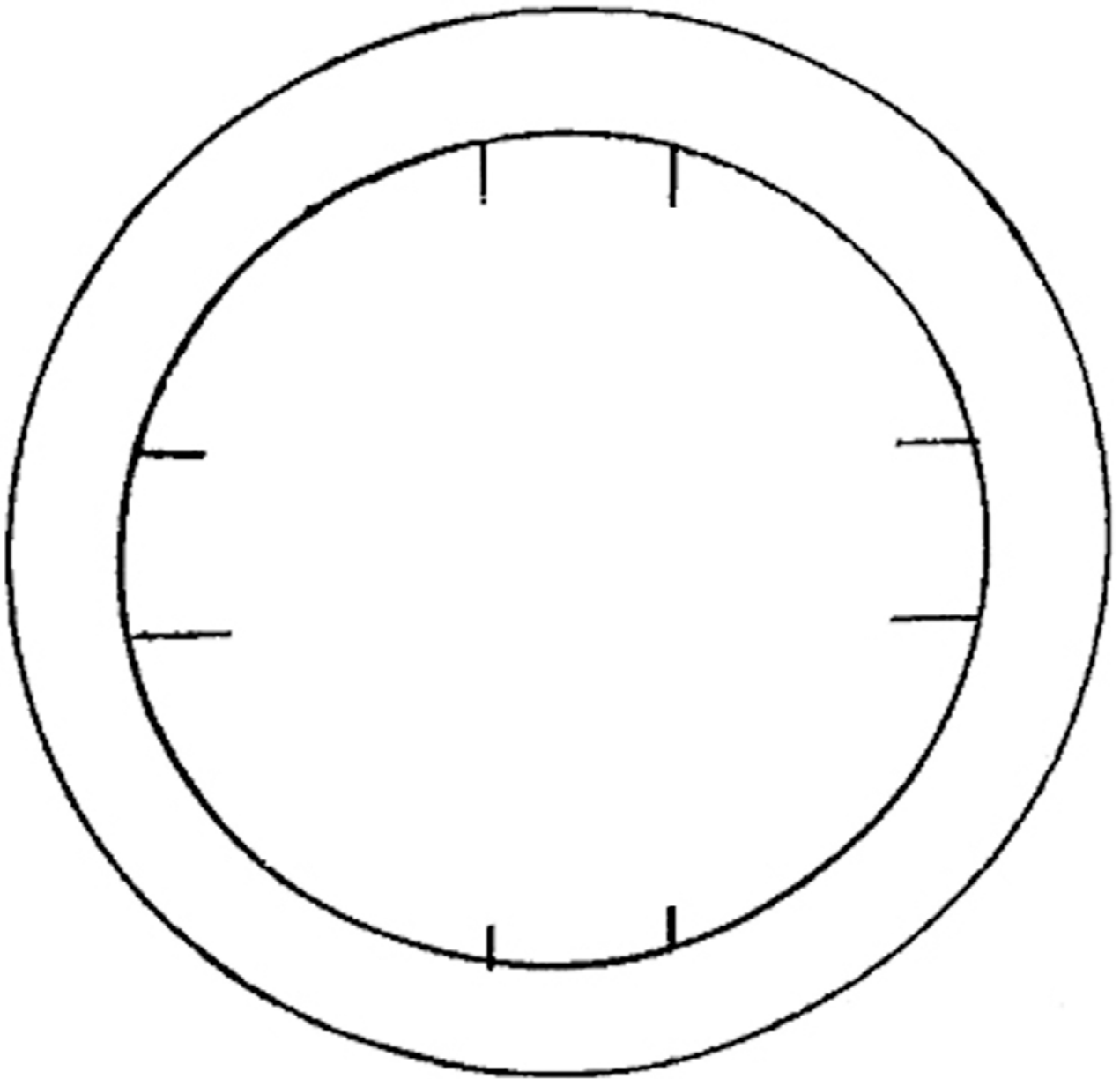

On that day many will say to me "Lord, Lord, did we not prophesy in your name, and do many mighty works in your name?" And then I will declare to them, "I never knew you; depart from me, you evildoers." Matthew 7:22, 23

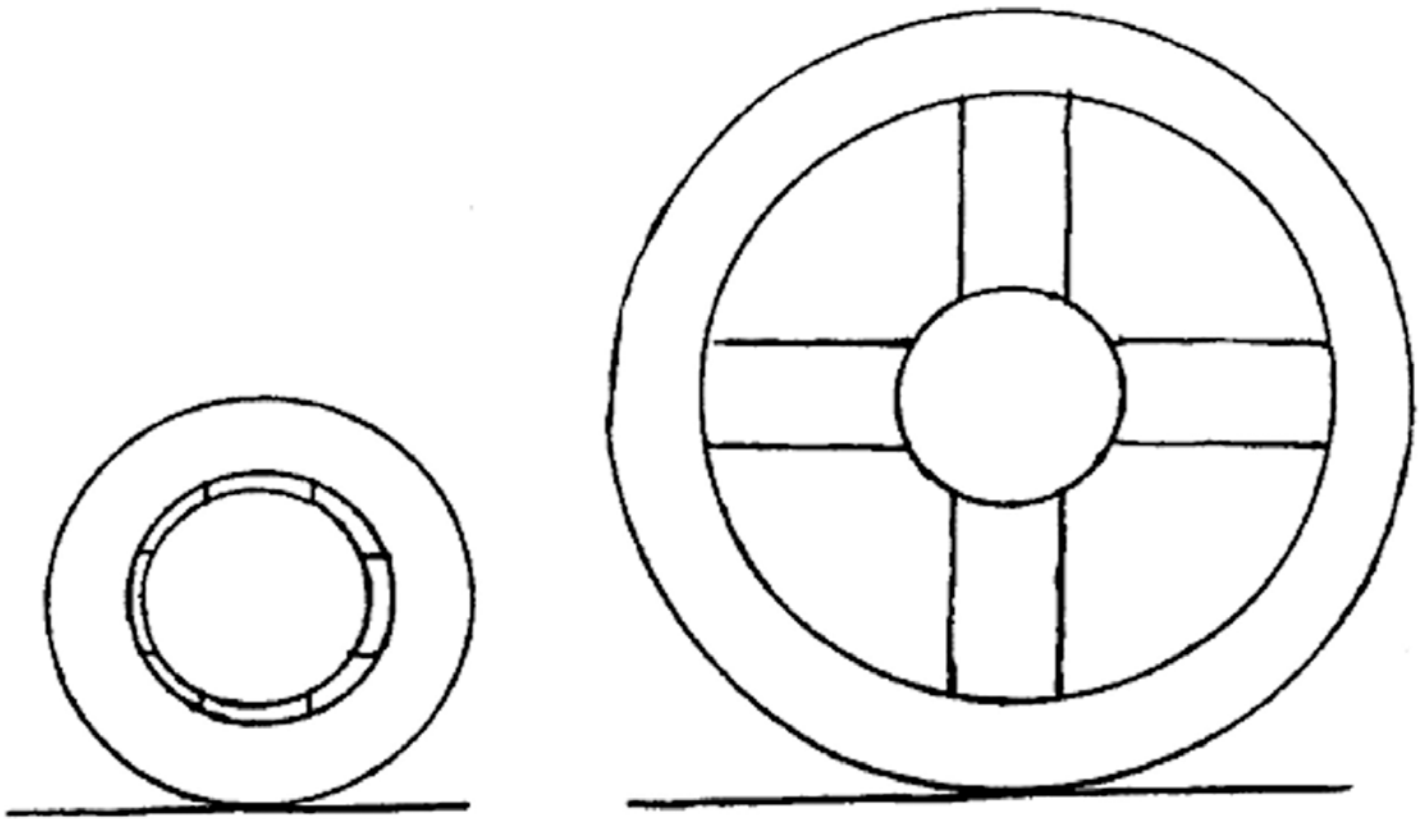

Like newborn babes, long for the spiritual milk, that by it you may grow up to salvation, for you have tasted the kindness of the Lord. I Peter 2:2, 3

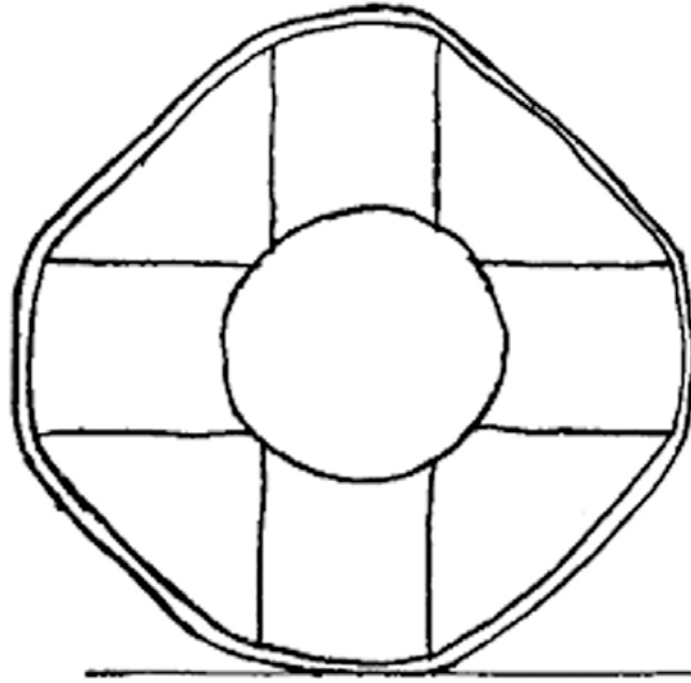

But be doers of the Word, and not hearers only, deceiving yourselves. For if anyone is a hearer of the Word, and not a doer, he is like a man who observes his natural face in a mirror; for he observes himself and goes away and at once forgets what he was like. But he who looks into the perfect law of liberty, and perseveres, being no hearer that forgets, but a doer that acts, he shall be blessed in his doing. James 1:22-24

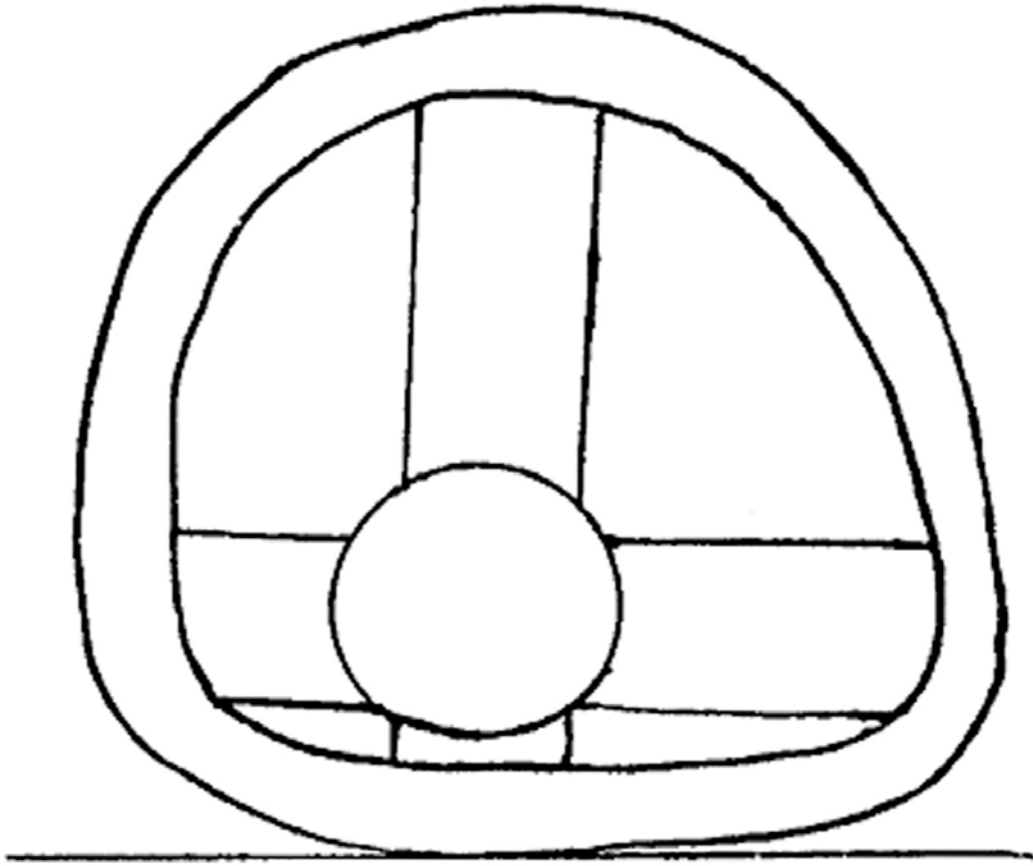

This book of the law shall not depart out of your mouth, but you shall meditate on it day and night, that you may be careful to do according to all that is written in it; for then you shall make your way prosperous, and then you shall have good success. Joshua 1:8

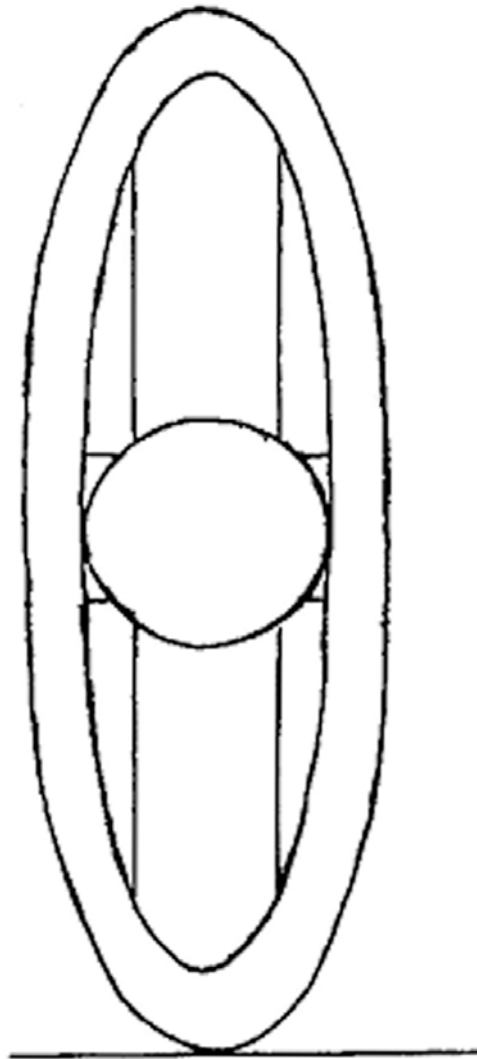

Him we proclaim, warning every man, and teaching every man in all wisdom, that we may present every man mature in Christ. Colossians 1:28

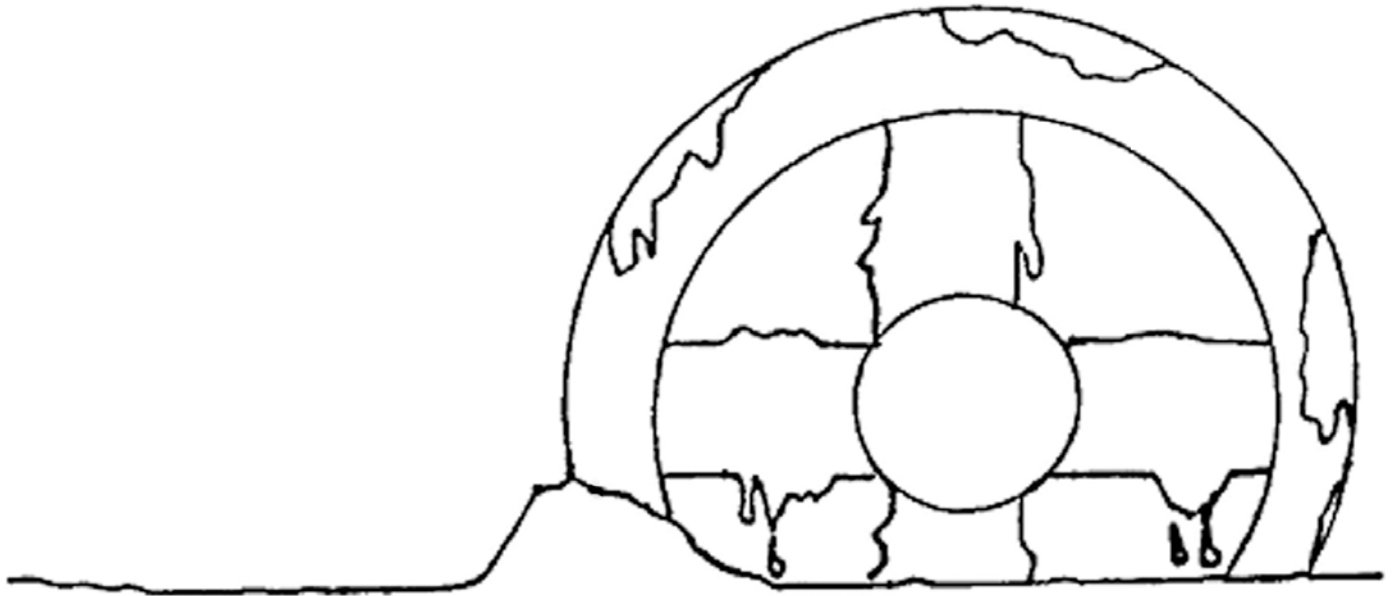

Do not be conformed to this world, but be transformed by the renewal of your mind, that you may prove what is the will of God, what is good, and acceptable and perfect. Romans 12:2

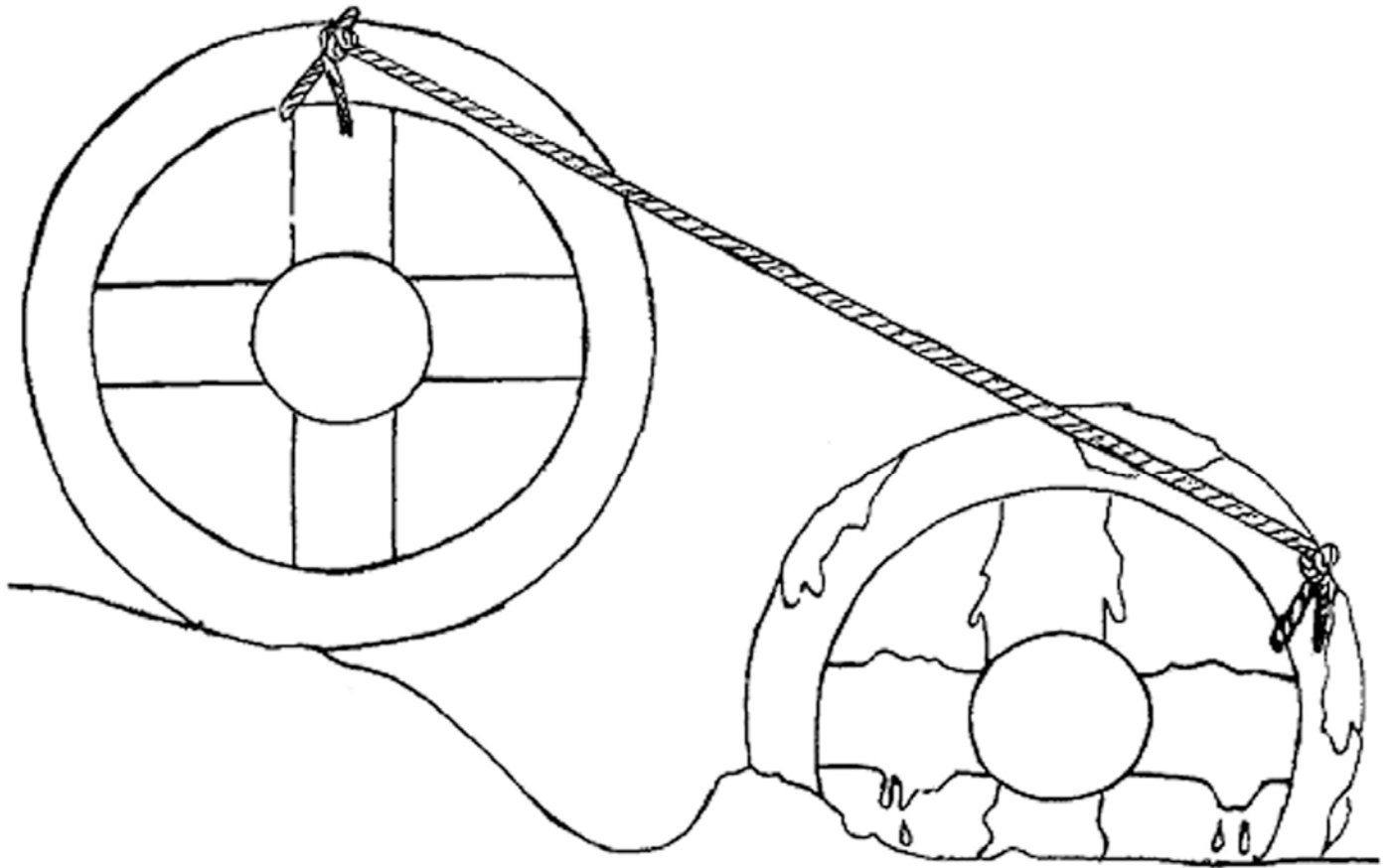

Brothers, if someone is caught in a sin, you who are spiritual should restore him gently. But watch yourself, or you may also be tempted. Carry each other's burdens, and in this way you will fulfill the law of Christ. Galatians 6 :1 ,2

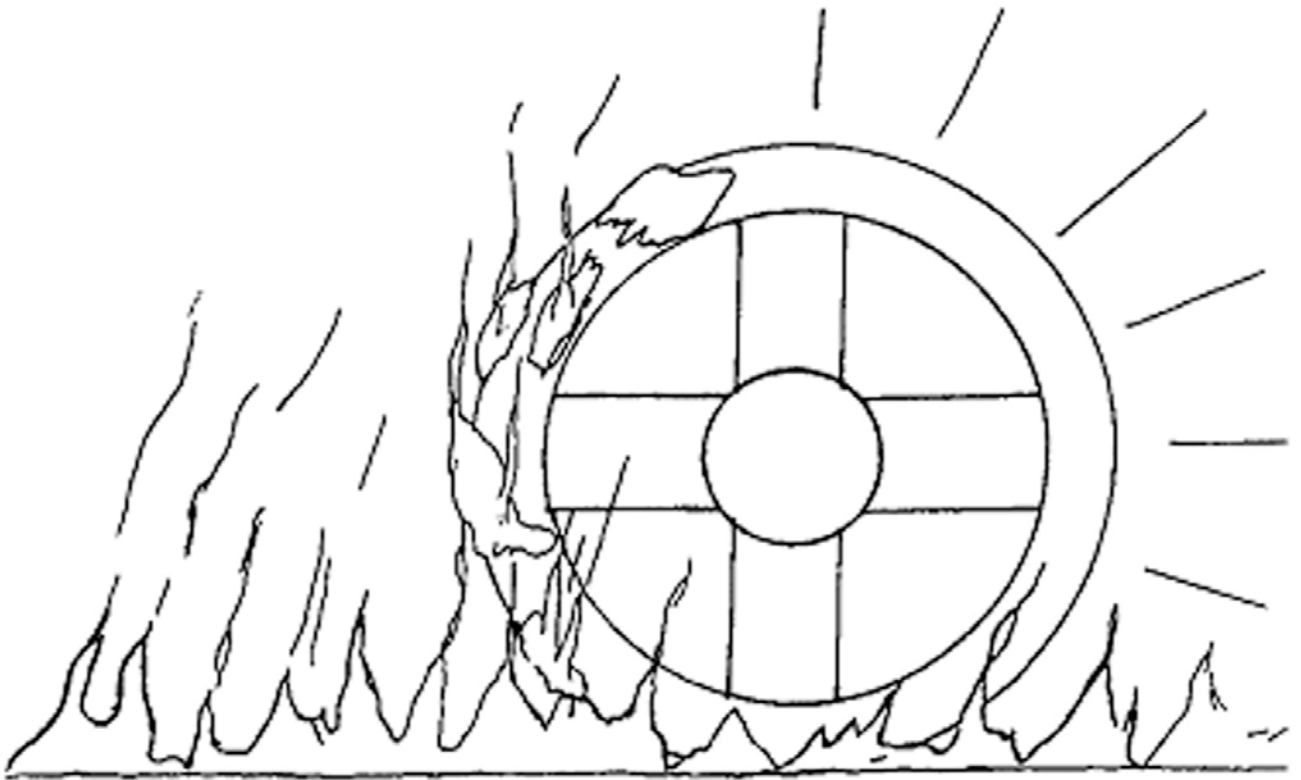

In this you greatly rejoice, though now for a little while you may have had to suffer grief in all kinds of trials. These have come so that your faith — of greater worth than gold, which perishes even though refined by fire - may be proved genuine and may result in praise, glory and honor when Jesus Christ is revealed. 1 Peter 1:6, 7 Blessed is the man who perseveres under trial, because when he has stood the test, he will receive the crown of life that God has promised to those who love him. James 1:12

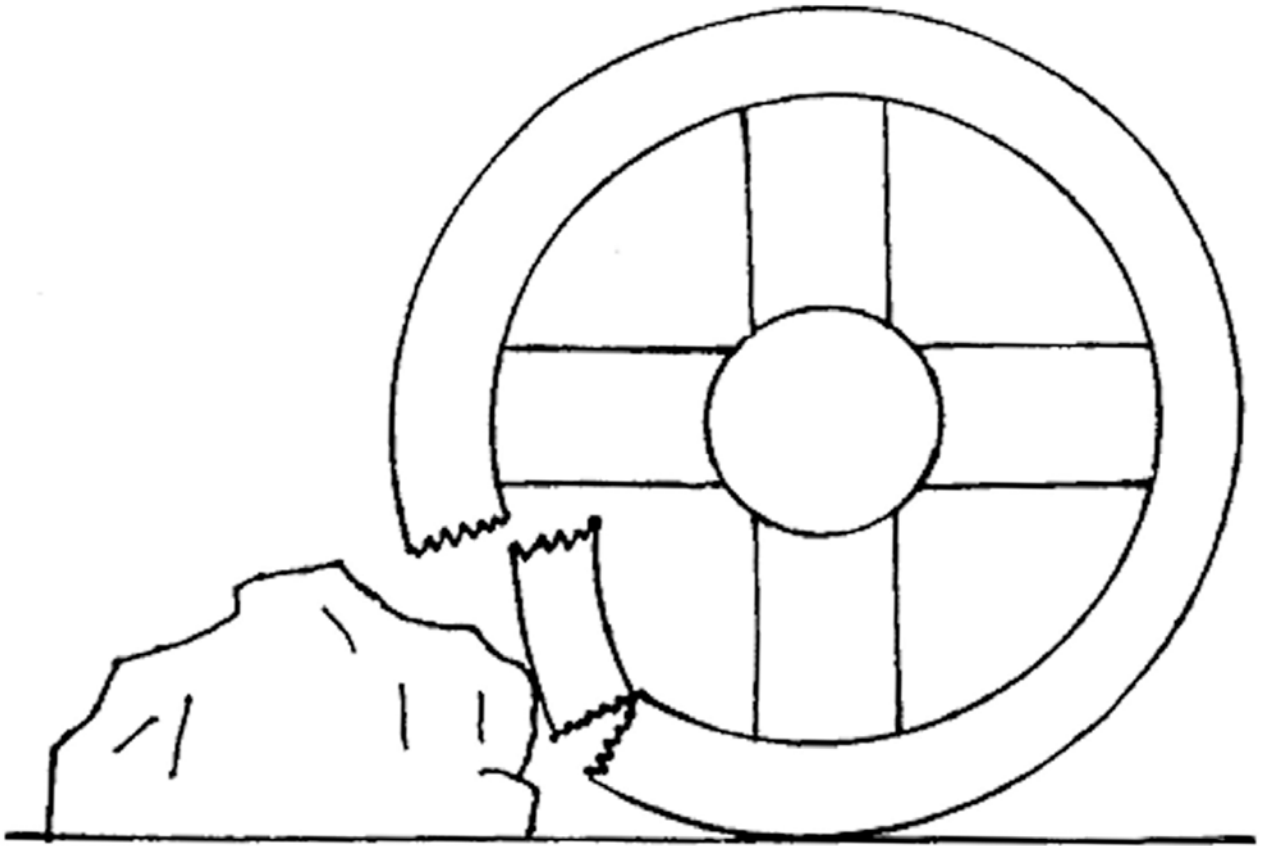

And lo, a woman meets him, dressed as a harlot, wily of heart. She is loud and wayward, and her feet do not stay at home. With much seductive speech she persuades him; with her smooth talk she compels him. All at once he follows her... Proverbs 7:10, 11, 21, 22

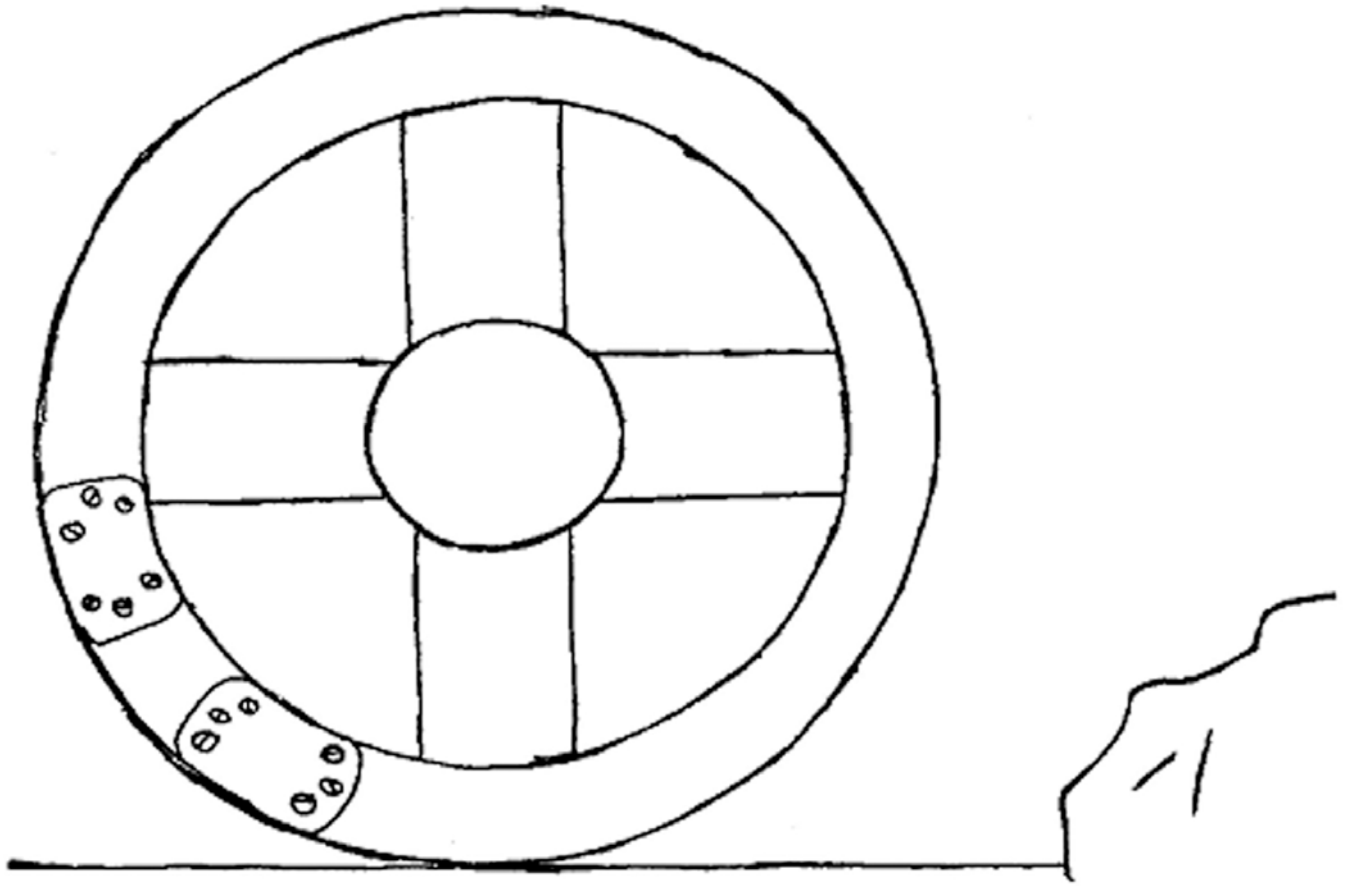

If we confess our sins, he is faithful and just, and will forgive our sins and cleanse us from all unrighteousness. 1 John 1:9

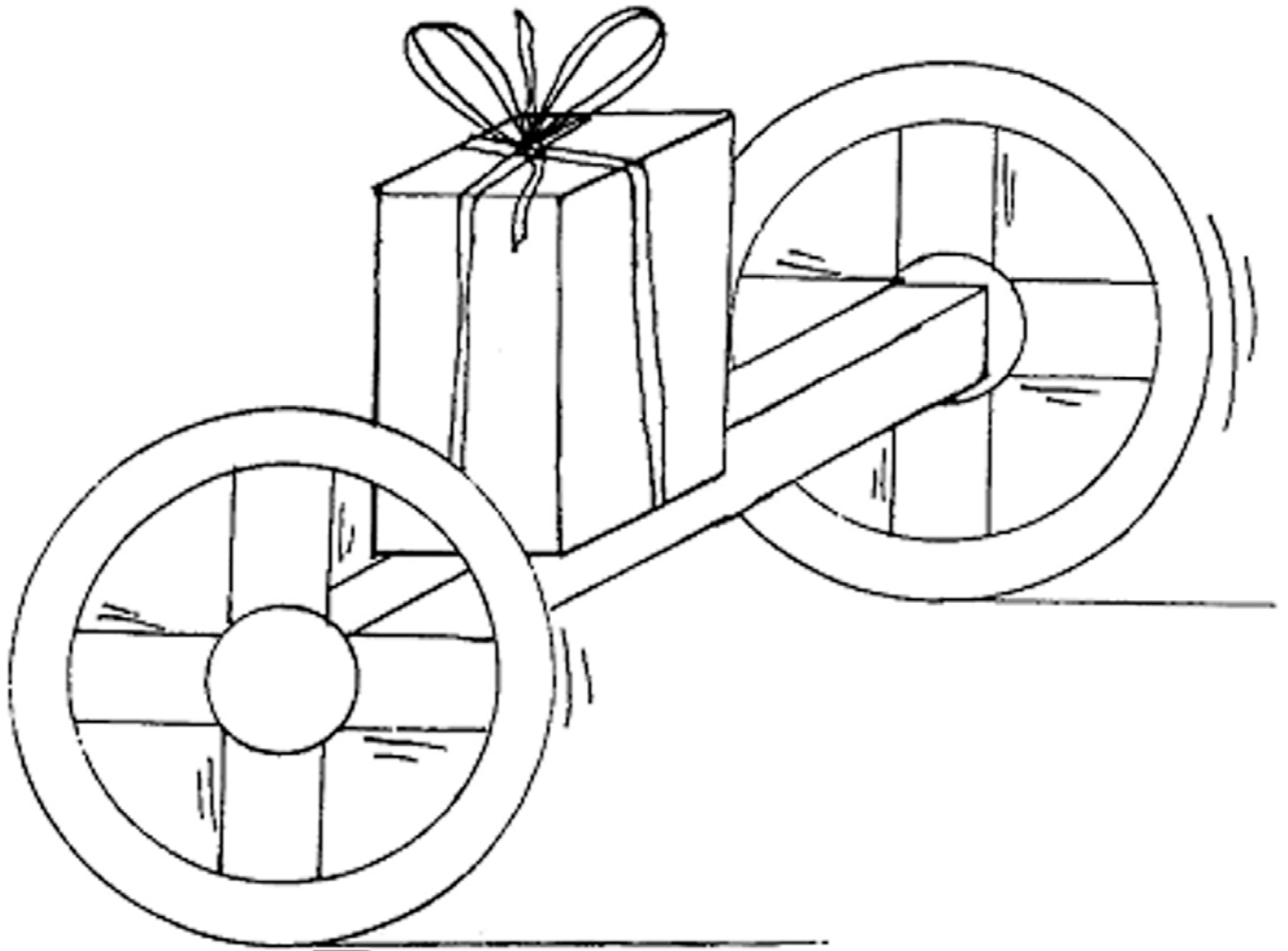

For where two or three are gathered in My name, there am I in the midst of them. Matthew 18:20 For the wages of sin is death, but the free gift of God is eternal life in Christ Jesus our Lord. Romans 6:23

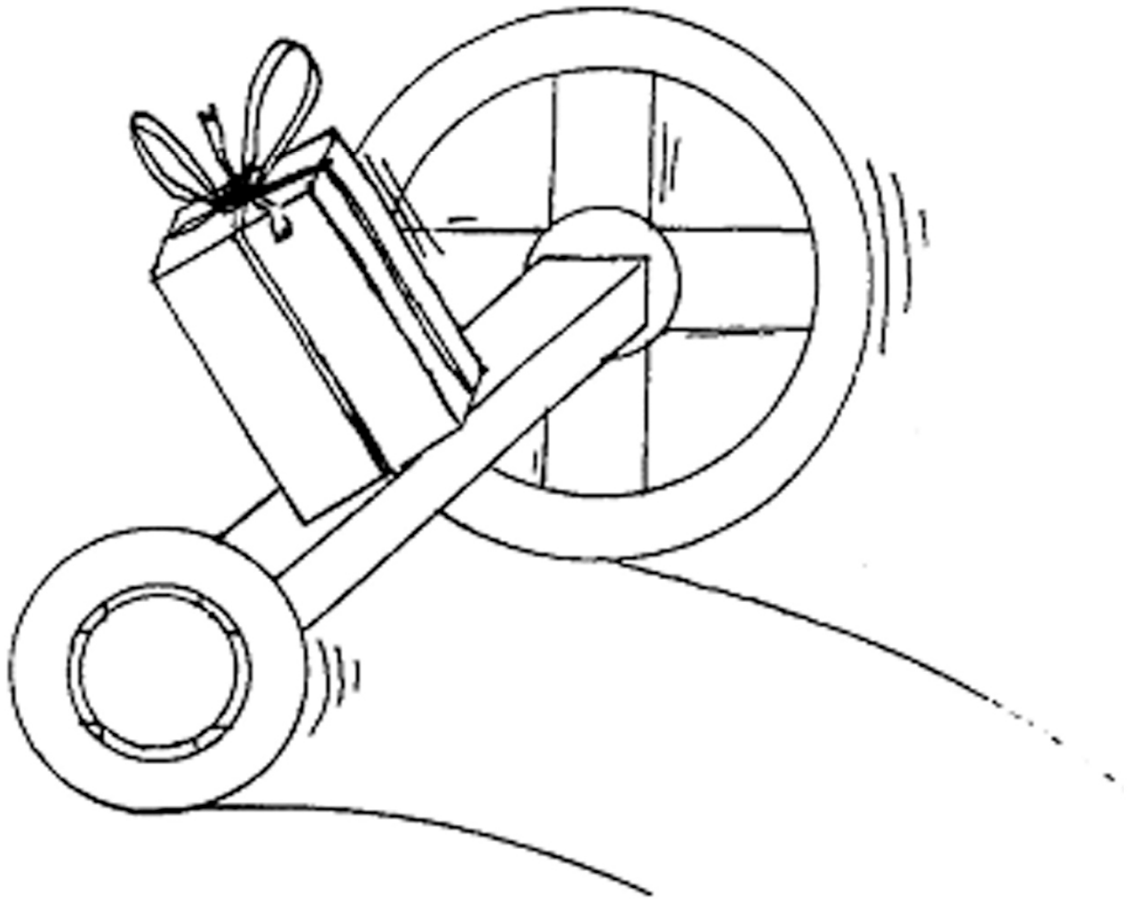

For though by this time you ought to be teachers, you need someone to teach you again the first principles of God's Word_ You need milk, not solid food; for everyone who lives on milk is unskilled in the Word of righteousness. Hebrews 5:12, 13 And what you have heard from me before many faithful witnesses entrust to faithful men who will be able to teach others also. 2 Timothy 2:2

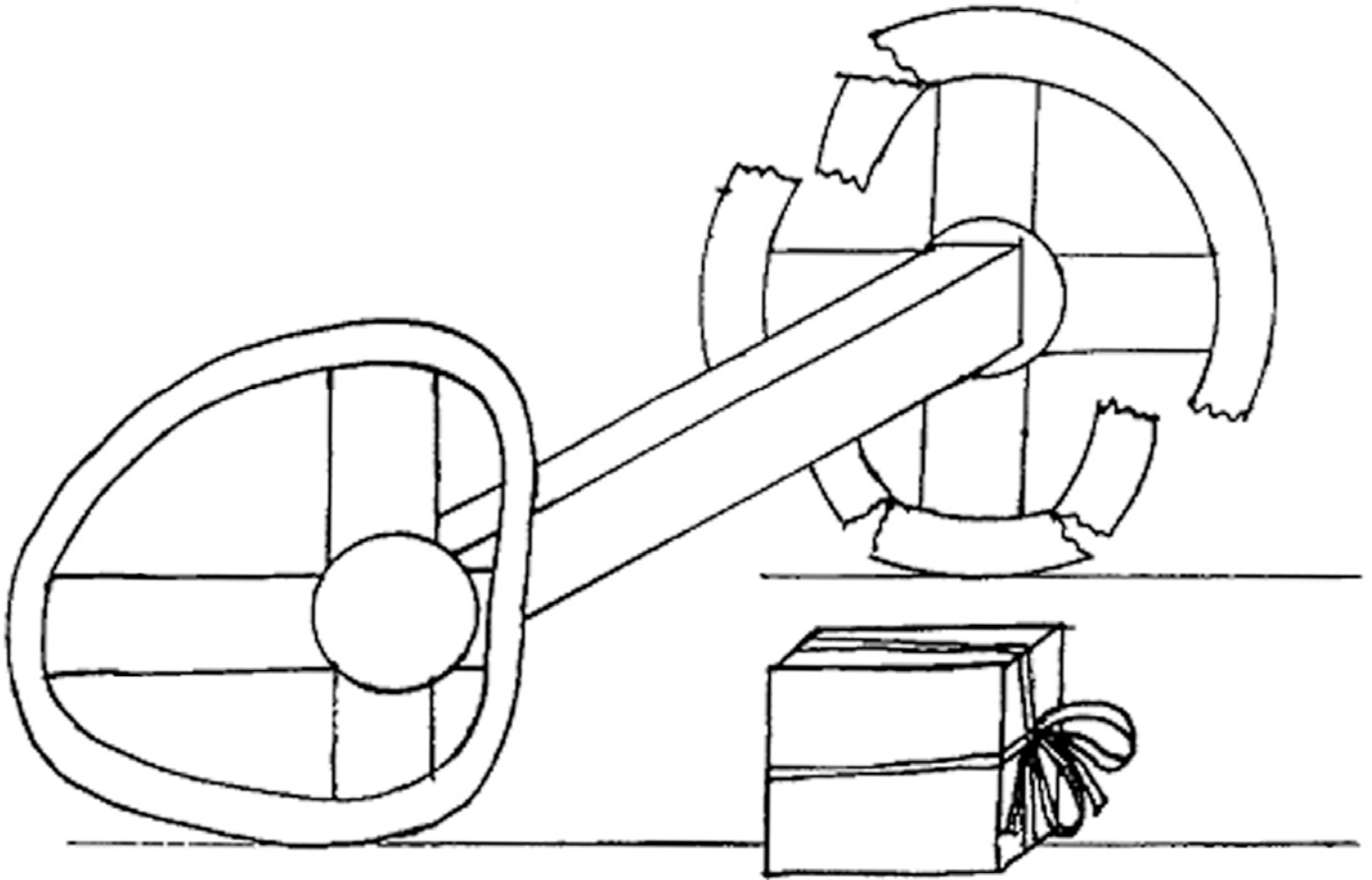

You who boast in the law, do you dishonor God by breaking the law? For, as it is written, "the name of God is blasphemed among the gentiles because of you." Romans 2:23, 24

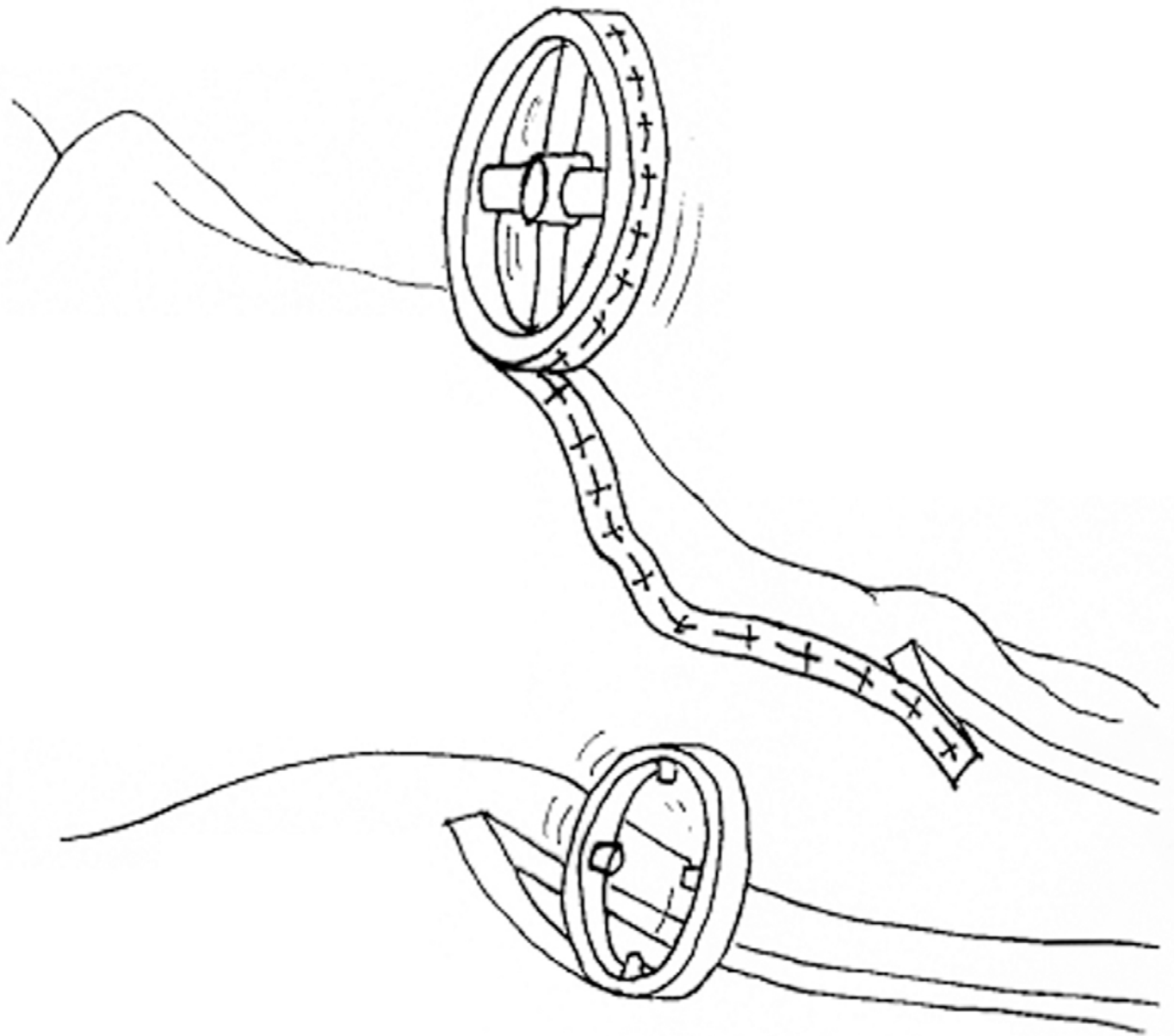

My help comes from the Lord, the Maker of Heaven and earth. He will not let your foot slip,
He who watches over you will not slumber. Psalm 121:2, 3

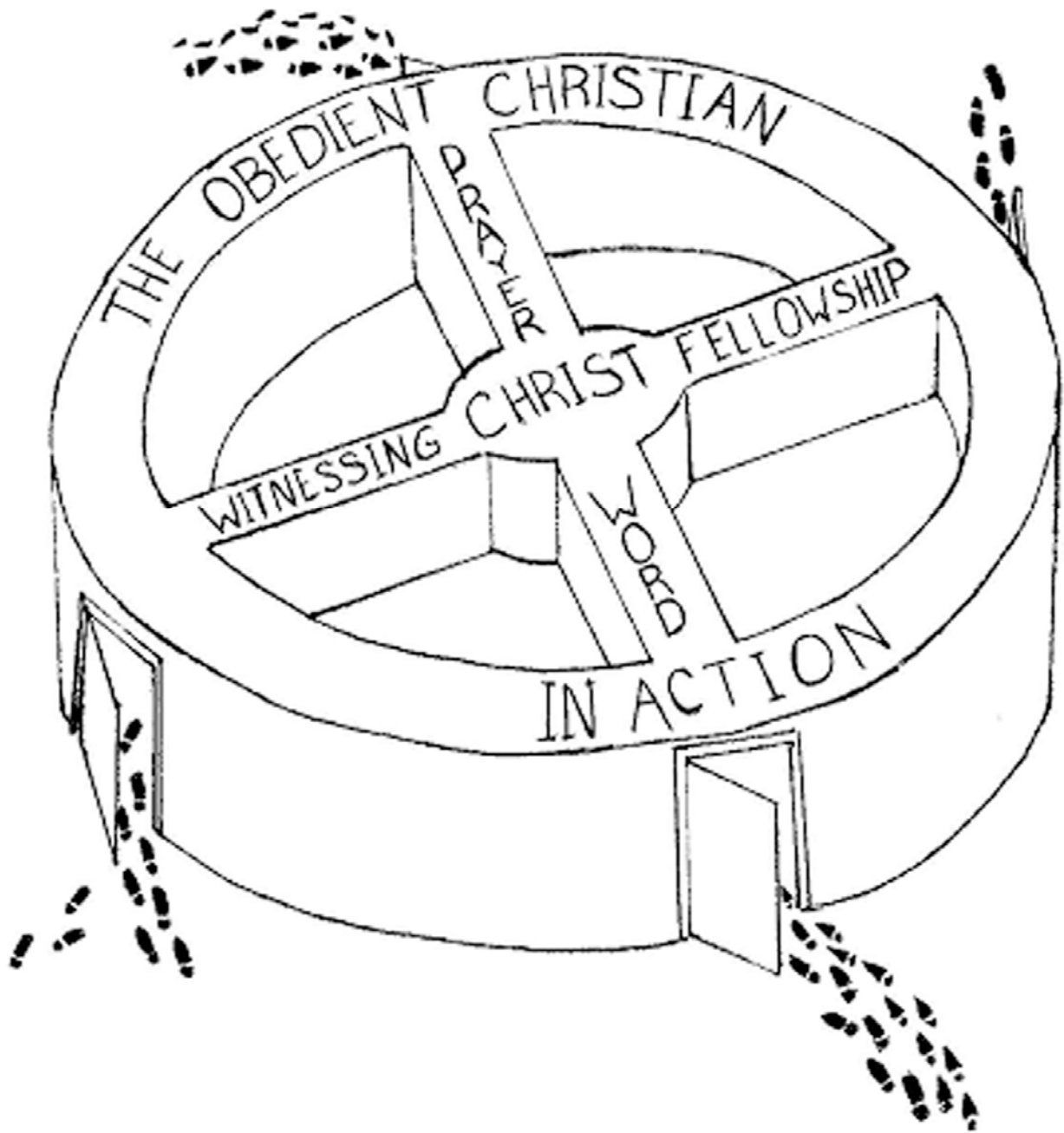

Don't you know that you yourselves are God's temple and that God's Spirit lives in you?
I Corinthians 3:16 (NIV)

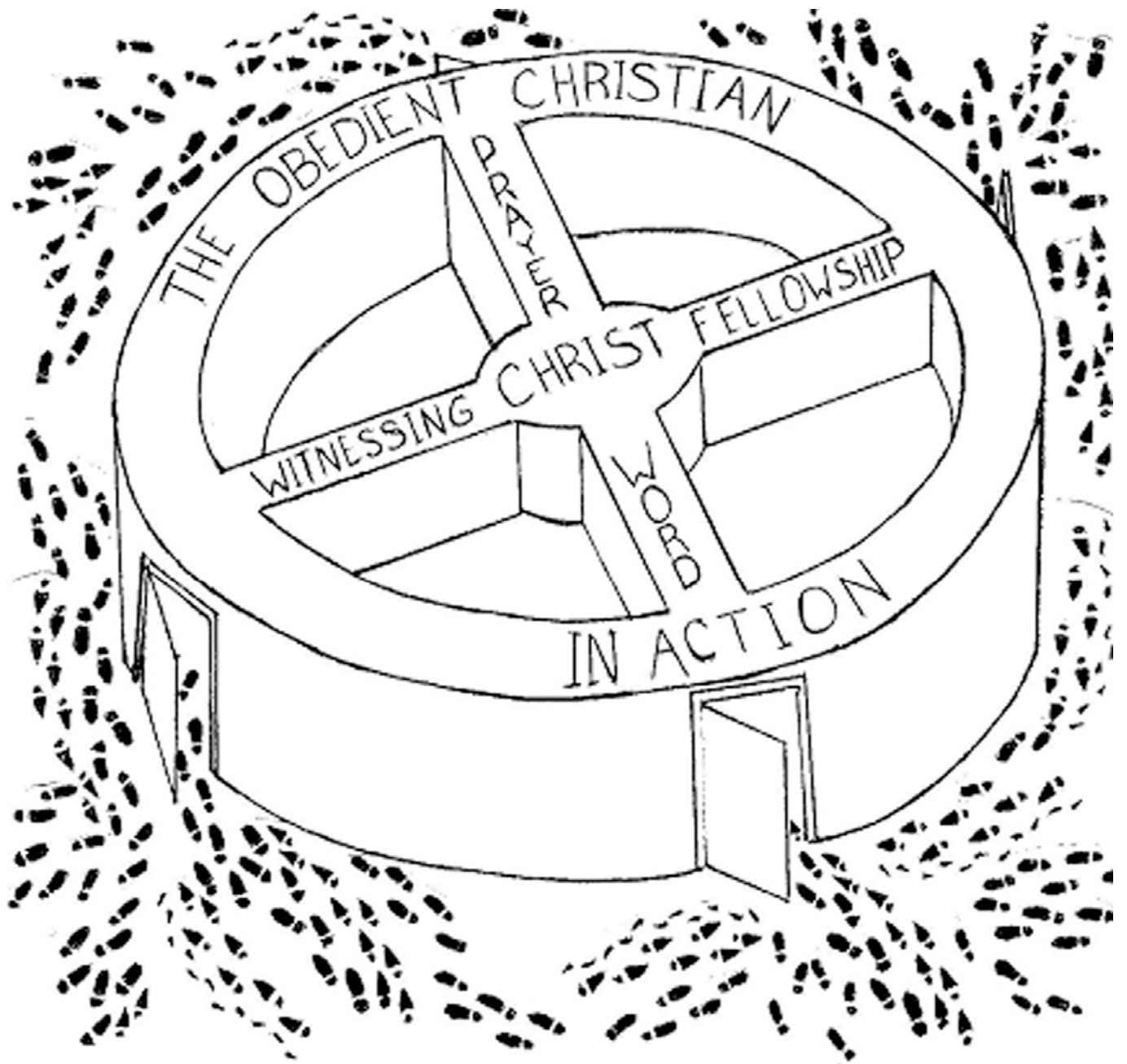

Since you are precious and honored in my sight, and because I love you, I will give men in exchange for you, and people in exchange for your life. Isaiah 43:4 (NW)

The Big Dipper

Dawson Trotman

*A **Final Message** - On June 18, 1956, Dawson Trotman, founder of The Navigators, triumphantly entered into the presence of the Lord while saving the life of another from drowning in the icy waters of Schroon Lake, New York. The following condensed message was given by Daws to a Navigator conference at Glen Eyrie, Colorado on June 14, 1956 - just four days before his death. This talk reflects the concerns that were uppermost in his mind and heart and, in a sense, summarizes the early Navigator emphasis.*

*The "Big Dipper" is a grouping of seven stars within the northern constellation called Ursa Major, or Great Bear. Together the seven stars form an arrangement that resembles a ladle. The two stars on the end of the cup are called "pointers" because they line up with, point to, the North Star - for centuries the guiding light used by sailors to navigate at sea. Dawson Trotman's final message, **The Big Dipper** lines up with, and points us to the living Word of God, our Lord Jesus Christ - the Guiding Light for all Navigators who set sail on the sea of life.*



May 1948, Paris, France: It was a beautiful starry night. I laid out on the flat of my back on the roof of the George V Hotel looking up into the heavens and reflected on the Lord who had created all these things and called them by name. While I was looking at the stars and thinking, I was prayed and meditated on some Scripture. I prayed something like this: *Lord,*

is there something in the Navigator work that we are omitting or failing to do that is displeasing to You? Is there something you don't want us to be doing? What are we doing that brings you pleasure?

Fundamentals of the Navigator Ministry *The Big Dipper Illustration*

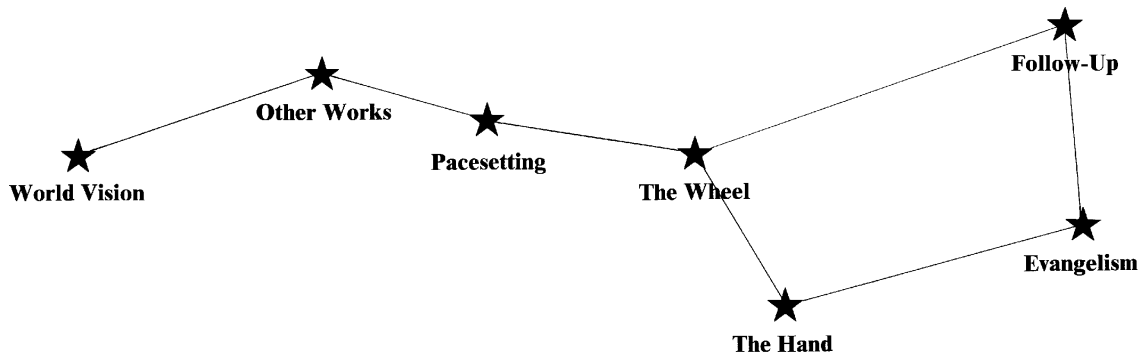

I happened to be looking up there at *The Big Dipper*. I studied those seven stars with four forming the bucket and the three out there as the handle. As I was thinking and meditating, an idea came to me. People can remember the Christ-centered, Spirit-filled life if they can see the picture of *The Wheel*.

Christ-centered Spirit-filled Life *The Wheel Illustration*



Suppose your life is like a wheel. Let me suggest how you might get this wheel moving for God. At the heart of the wheel is Christ; Christ is the hub. From this hub comes your driving

power, your guiding power, and your holding power. The hub is attached to the axle which is attached to the drive shaft, and hence, to the motor. Because Christ is at the heart of the Christian life, we are called Christ-ones, or Christians. "*That in everything, He might have the supremacy*"(Colossians 1:18). From Him comes our life, our power to victory, and our all sufficiency.

Let me suggest four spokes that connect the hub to the rim. Two spokes that tie the Christian into a living relationship with Christ are *The Word* and *Prayer*. In the Word, He speaks to us, and in prayer, we speak to Him. These perpendicular spokes are the two means of grace that have been given so that we can have fellowship with God. It is out of the Bible that we learn how to pray. That's why I have placed the Word on the bottom as the foundational spoke. Hundreds of times throughout Scripture, we are not only advised, but commanded to obey the Word of God. *Obedience* is the secret to get this wheel in operation.

The fourth spoke is what I would call *Witnessing*. It is the responsibility not just of the preacher, the evangelist or the full-time worker. It is not an exercise but a lifestyle. It is a command given to us all. It is not optional, but imperative. Many people feel that the fourth and final spoke of this wheel should be the Church. But the church is not just a single spoke' it is the entire Wheel. It's a lot of Wheels working and moving forward together.

So the main basic things are The Word (Scripture), Prayer, Fellowship, Witnessing, Obedience. I put that principle, The Wheel, on the pivotal star of the dipper. It carries the weight between the handle and the bucket. It is the lever that supplies the hinge or support for all the rest.

We in The Navigators stress the Bible quite a bit. The five ways of getting a grip on the Scripture are pictured in *The Hand*.

A Balanced Intake of God's Word

The Word Hand Illustration

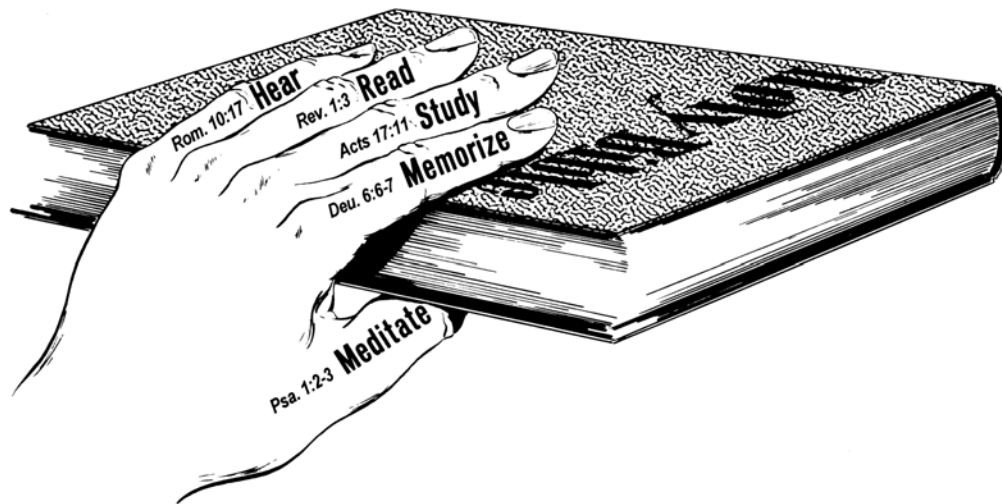

Knowing it by Hearing, Reading, Studying, Memorizing, and Meditating. Each one of these is dependent upon the others. If any one is missing, you have a deformed hand. We must have all five methods of intake if we as soldiers of The Cross are to handle aright the sword of the Spirit.

The first two stars are the backbone of our work the balanced Christian life revolving around the Lord Jesus Christ, and the importance of *The Word of God*. Without these, there is no production for God.

Then I thought, "What's another emphasis of The Navigators?" Why, naturally: *Evangelism*. It's the very heartbeat of our ministry. As in the dipper that I saw in the sky, the third star is the scoop. It's the blade with which you dig. Without evangelism you haven't got anything. It is the cutting edge. Our aim was for new Christians to learn to reach out to others; otherwise it is like being born sterile, they don't reproduce. You reach out with a shovel and scoop up but what do you need on that shovel to make a real dipper? We want a backside to hold in the contents. You need something to conserve that which you have picked up. This is the fourth star that I saw that night in Paris.

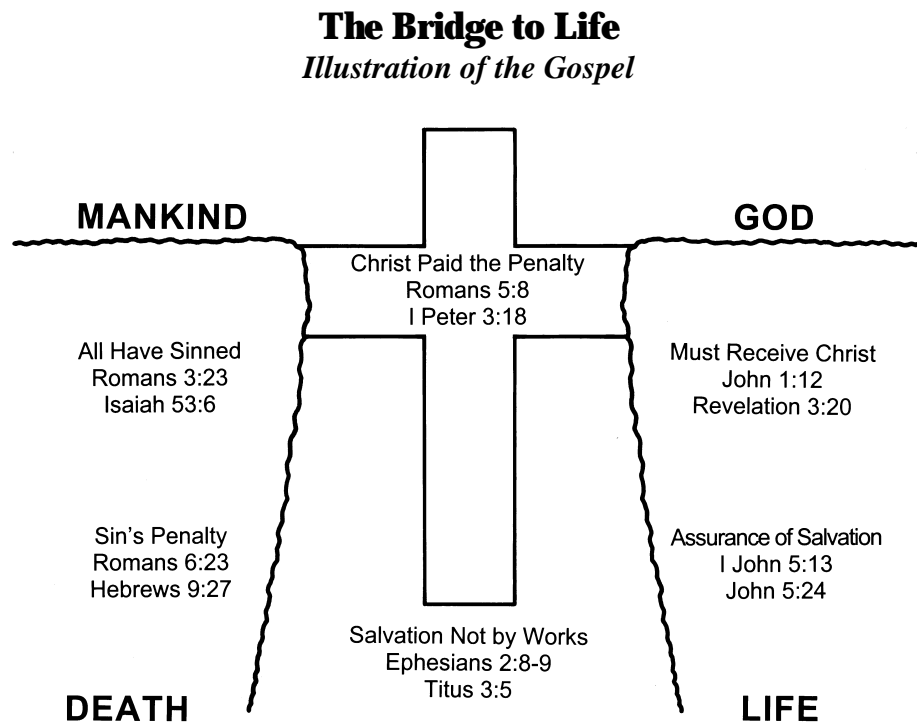

The thing that holds your people once you've won them to Christ is *Follow-up*. By follow up, we don't mean just sending in a name of a convert to their church or having a quick word of prayer with an inquirer at the altar. Follow-up is an attitude... it is a process... it is a commitment. We start with an individual the minute he turns his or her life over to Christ... He is a baby. We start just like a mother starts with her baby when it is born. The doctor doesn't say, "Well, now that's a healthy baby boy. I can see you won't have to bother with

that one for about a week. Let's see, this is Sunday; be sure to come back and we'll see how your baby is doing. Why is it that we leave a new baby Christian alone a whole week until he gets to the next service or meeting - if he does? Who can tell me who's busy with him right away? The old devil! And he isn't going to say, "Let's have fair play here. This poor baby isn't getting taken care of properly. I'll not tackle him until a week from Monday." That just doesn't happen.

We believe in follow-up. These last two stars form the dipper and they are what we call reproduction... evangelism and follow-up. But there will be no reproduction until there is production. These four stars make up the main emphasis of life and ministry.

The Christ-centered Spirit-filled life: we're always trying to get folks into a strong devotional life, always trying to get people into the Word of God, always fighting to get them to take care of the ones they win. Well, now, what else do we really believe is basic? What else is there that we are willing to give our lives for?

One thought crowded into my mind ***Pacesetting***. It is the one thing that gives a handle to production and reproduction. I realize that pacesetting is a poor word. Let's get another word or two. How about *example*, or *your life the embodiment of the first four stars*? Other words you might use are *pattern*, *model*, or *prototype*. To give you Scripture on it, let me start with Matthew 4:19. Jesus didn't say to his men, "Now listen to me and I'll make you fishers of men." What did He say? Not "listen to me," but "follow *me*." In other words, we learn by seeing, not just by hearing. That's one of the problems much of our present-day education. We sit at desks for twelve years and primarily listen. Teaching is definitely not just telling, but it is also showing.

Here is a super-duper verse in Bible on the subject - Philippians 4:9... this is dynamite: *Whatever you have learned or received or heard from me, or **seen in me** put it into practice. And the God of peace will be with you.* That's the Christian life, gang. Would you rather have for a teacher a person who only knew a little of the Bible but it was a part of his life, and he lived it, or a man who knew the Bible from Genesis to Revelation who wasn't living it? How many will take the man who knew less but who's living it? But it doesn't have to be "either-or"... I'll go for "both-and". I want to be a man who both knows the Bible from cover to cover and also lives it! Edgar Guest wrote,

*I'd rather see a sermon
Than hear one any day:
I'd rather you would walk with me
Than merely tell the way.*

*The eye's a better pupil
And more willing than the ear;
Fine council is confusing,
But example's always clear.*

*The best of all the preachers
Are men who live their creed,
For to see good put into action,
Is what everyone needs.*

*I can soon learn how to do it,
If you let me see it done,
I can catch your hands in action,
But your tongue too fast my run.*

*And the lecture you deliver
May be very wise and true,
But I'd rather get my lesson
By observing what you do.*

*For I may misunderstand you
In the high advice you give,
But there is no misunderstanding
How you act and how you live.*

*When I see an act of kindness,
I am eager to be kind;
When a weaker brother stumbles,
And a stronger stays behind.*

*Just to see if I can help him,
Then the wish grows strong in me,
To be as big and thoughtful
As I know that friend to be.*

*And all travelers can witness
That the best of guides today,
Is not the one that tells them,
But the one that shows the way.*

I love that, and yet, it's so easy to go off to school and tank up on a bunch of facts and figures and then try to go transmit those facts and figure by the voice or by the written page. Jesus didn't do it. He was always leading by example. "As Christ suffered, leaving us an *example* that you should follow in His steps" - I Peter 2:21. I find it much easier to talk with sinners because Jesus did. It makes the difference. And that's what we mean by pacesetting. I Thessalonians 1:5 says this: *because our gospel came to you not simply with words, but also with power, with the Holy Spirit and with deep conviction.* It came with assurance because you, the Thessalonians, *You know how we lived among you for your sake.* It isn't that everything you hear me say you may see me do, but there will be just enough that you do see... that you can tell whether we are sterling silver or just silver-plated.

Just one other verse: *Follow my example, as I follow the example of Christ (I Corinthians 11:1)*. Paul knew that he followed the Lord, and he knew that if the people in Corinth would step where he was stepping, they would step where Jesus stepped. To follow Paul was to be in step with Jesus Christ. I can't give that verse very often, but it's a goal... It's the desire of good dads and mothers. It's the very heart of good teaching. A father hears his little boy tell a buddy, "When I grow up, I want to be just like my daddy!" Whether it be in living the Christ-centered life, or a consistent commitment to the Scriptures; whether it be daily sharpening the cutting edge of evangelism or discipline to nurture my converts until they are mature in Christ... all these factors demand pacesetting and example-setting on our part.

"Lord, what is something else big that's on Your heart?" I asked, and a verse of Scripture went through my mind. *Your attitude should be the same as that of Christ Jesus*. The concept popped into my mind. Yes, that's an emphasis with us... We want to be servants to others – **Other Works**. But the verses just before verse 5 in Philippians 2 stood out bright and clear... even as the middle star on the handle of The Big Dipper. Put these verses down in big letters. This is the missing link in the body of Christ.

The Lord so burdened me with the concept found in verses 3 and 4 that I could hardly keep back the tears. I'm thankful that it had already begun in our ministry but it wasn't strong enough. It was out on the fringe, not at the center. *Do nothing out of selfish ambition or vain conceit, but in humility consider others better than yourselves*.

Who do you know who truly believes that others (churches, organizations, fellowships, denominations, mission boards, ministries) are better than they are? A sure cure for criticism: *but in humility consider others better than yourselves* Now the very next verse in Philippians 2 says, *Each of you should look not only to your own interests, but also to the interests of others*. This means what others are doing - their words, their plans and their ministry.

The tendency today is for me to feel that my denomination is superior, and all others are inferior. The reason that idea affects you negatively is because you *know* the Methodists are better than all these others, because you are a Methodist. That would be true whether you are a Baptist, Lutheran, or Catholic. You never hear anybody saying the other denominations are better.

It's the same thing that every nationality feels. Superiority! We all feel better than others. It's human nature; it's part of our heredity. Yet in God's sight, they are all the same. The yellow man isn't any better than a black man or a white, nor is a white man better than any other man. But just try to make yourself believe that, or even worse, try to get others to really believe it.

There emerged in my heart and mind that night the thought that The Navigators must not work just for The Navigators, nor try to build the Navigator organization, but must work for the church - not just *a* church, but *the* church... all churches. Maybe they don't agree on certain points of theology or order of worship, or doctrine, but any church where Jesus Christ is Lord... let's get behind them and push them.

The minute we hear of another Christian work or ministry, we should take time to find out, not what's wrong with it, but what's right about it and encourage them and give them a lift. We've emphasized it, but not nearly enough. I jotted down on the back of piece of paper what's costing me to have this emphasis, and it looks something like this:

- Wycliffe Bible Translators - Summer Institute of Linguistics
- Missionary Aviation Fellowship
- Missionary Communication Service
- International Students, Incorporated
- Youth for Christ, International
- The Billy Graham Team

Each of these means anywhere from one to three trips across the country a year. None of this is Navigator business, but is the King's business, and that's what we are involved in. It's costing us, but Proverbs 11:24-25 is still true: *One man gives freely, yet gains even more; another withholds unduly, but comes to poverty. A generous man will prosper; he who refreshes others will himself be refreshed.*

A person just can't out give God. In 1950 I was to take a world trip costing \$3,100 and we didn't have a dollar for it when I ordered the ticket. The weekend came when I was to have the money or they would cancel the ticket. I prayed and waited upon the Lord.

We were in Washington, D.C. with the Billy Graham Campaign, helping with the counseling and follow-up. Saturday afternoon, Billy called me into his hotel room: "Dawson, you're going around the world pretty soon, aren't you?" "Well, I'm supposed to leave on Tuesday." "Got your ticket, yet?" "Not really; I need a little cash." Billy thought for a moment and then said, "You know what we'll do? Tonight after the regular offering, I'll call you up to the platform and have you give a short testimony and I'll tell the folks what you are going to be doing in the coming weeks around the world. We have been here in D.C. for three weeks and you haven't done this yet... We'll take a retiring offering for you and your work."

Boy, was that something! Well, Billy had me up there, he said some nice words, and then he told the audience he wanted them to help send me overseas. "Mr. Trotman will be here at the front of the auditorium... You come up, shake his hand and leave something in his hand for the trip." The first fifty to the front after the service were cute little "bobby soxers" who wanted my autograph in the Crusade songbook.

They had me in a corner for forty minutes! No chance for anyone to put anything in my hand! Pretty soon a big old burly guy comes up and rescues me and says, "Come over here and take a look." There in a suitcase was an overflowing pile of money. People were still coming up, and the meeting had been over for almost an hour. They gave me a police escort to the hotel, loaded suitcase and all. \$2,700 in pennies, nickels, dimes, quarters, and bills. There was \$1,200 in one-dollar bills, plus some fives and tens!

As I sat there on the edge of the bed counting the money, I thought, "Isn't it strange that the Lord would sent \$2,700 and not the needed \$3,100? He could have done it just as easily as He fed the five thousand people with the five loaves and two fishes."

But God knew that I couldn't buy my ticket until Monday morning, and Sunday I was in the Crusade meeting, and different men and women came and said, "Mr. Trotman, there were so many people up front last night, and since I wanted to meet you personally, I waited until today to slip this into your hand." Late that afternoon, after getting back to my hotel room, I counted what was in my right coat pocket. There was in my hand \$400. The total was \$3100!

We put our time and energy in these *Other Works* of God and He looks down from heaven and says, "Dawson, you can't out-give Me."

Gang, don't ever get into the Nav work if you are going to let the sunrise and the sun set on the Nav work. If it's in your heart and mind to serve the Lord's people by whatever stripe they may be called... if they belong to Him and love Him... be open to the possibilities of helping them as much as possible. We know this is what is on His heart and what He wants.

Do you think the Lord is going to let you down when you try to fulfill some of these calls and demands from other parts of His body? He can't! Not if we're obeying His Word.

Let me share with you about that last star, away out there on the end of The Big Dipper handle. It had now been two or three hours that I had been on that hotel roof, but I wasn't even aware of the cooling night air. I said to myself, "**World Vision** has got to be go out there on that last star." That's as far as you can get.

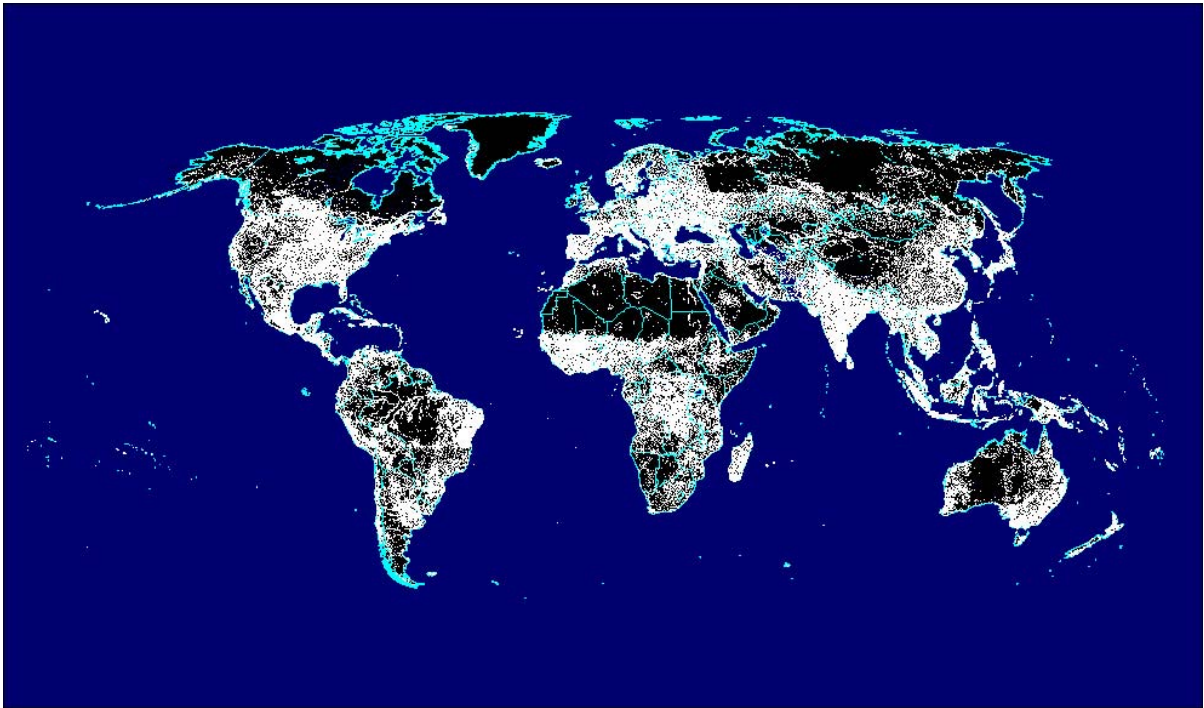

"I have made you a light for the Nations that you may bring salvation to the ends of the earth." Acts 13:47

This is the seventh emphasis that God laid upon my heart and no more... I believe there are many more things. We are still just learning all that God has for us. Never close your mind to what is on His heart.

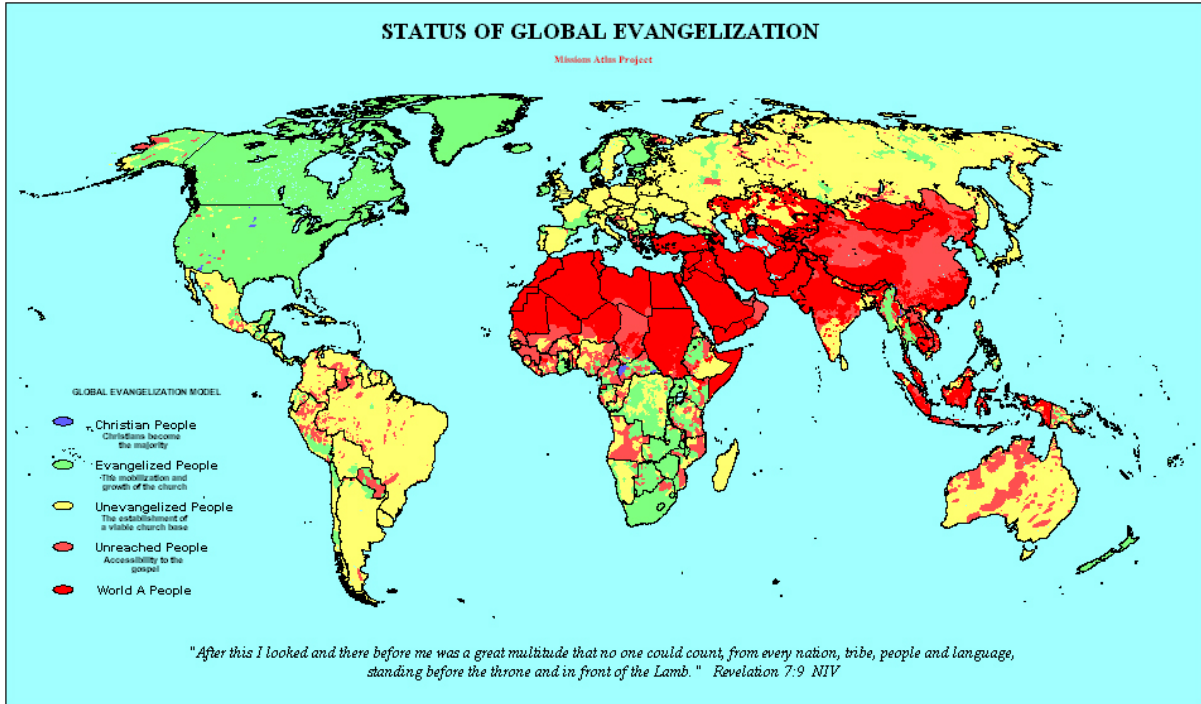

We teach world vision on the basis of the whole Bible, on the basis of the last words of Jesus Christ and on the basis of Acts 1:8. The Great Commission is to get the Gospel to every creature. Have you ever caught the idea that you are going to have a world vision? God wants every one of us to have more than a casual interest in every nation of the world to be concerned about what impact we can have.

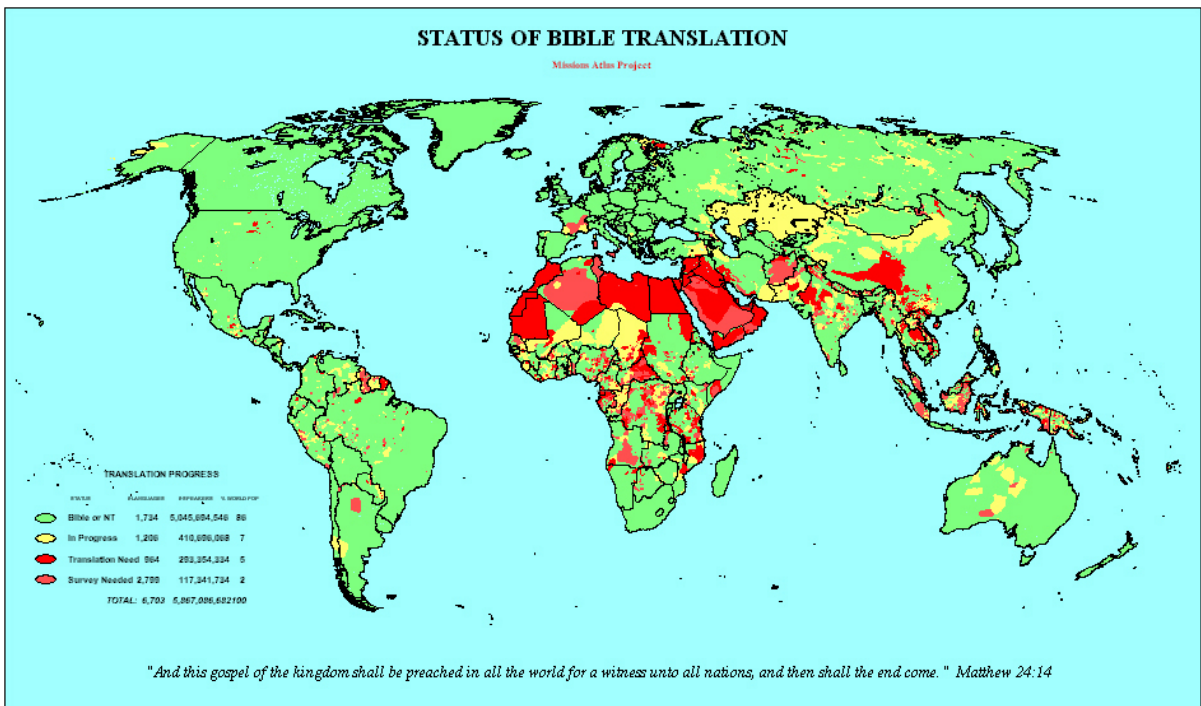

The Navigators are in many countries. Our goal is to serve in every major country of the world. We are not trying to start a new mission, but to go and give hands and feet and to serve the present groups that are already there or will be going there.

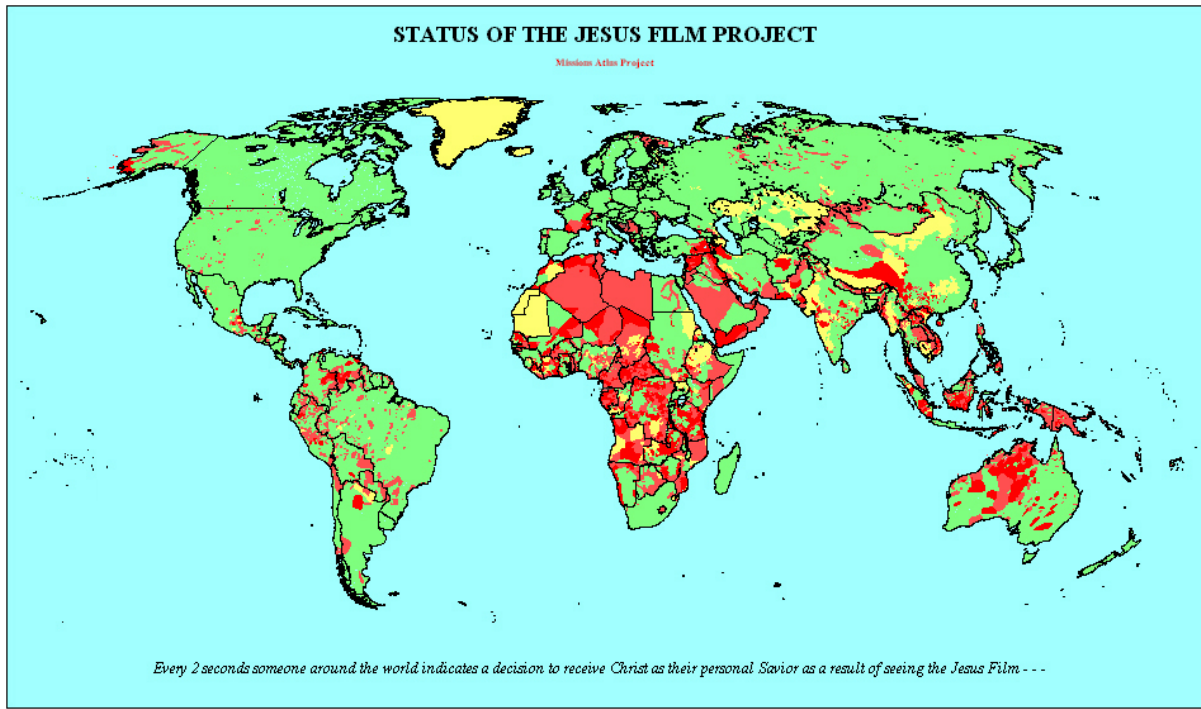

These last three stars form the handle that acts as the fulcrum. This is how we reproduce reproducers. It all starts with the Christ-centered, Spirit-filled life... That's the beginning of reproduction. Then we go into the Word of God and out into evangelism and follow up... That's reproduction. Not just one fruit tree for God's glory, but producing the seed from which will come many fruit trees which will reproduce orchards around the world, for His glory. Nothing less will do!

I trust I haven't been preaching at you, but I have wanted just to talk with you and share with you what has been on heart since that night on the roof of the Paris hotel. Now I want you to follow with me as I pray:

Lord, if anything has been said which is from You which You want to impart to these hearts, do cause it to remain and become a part of their lives. We do look to the Holy Spirit to put His seal on what is from You. And, Lord, if tonight I have done like I do so many times, gotten off the beaten path or said something that is not down the line or according to Your will, Lord, let it be as water poured out on the ground and cannot be gathered.

Now send this band of young people homeward, and may they not say they have been at a conference, nor been at Glen Eyrie, nor at a Navigator deal, but in some way let it be said they have been with Christ, and we ask it all in His dear name, Amen.

Lawson Trotman